

OPERATION MANUAL

HYDRAULIC HAND PALLET TRUCK



Note: Operator **MUST** read and understand this operating manual before use this hand pallet truck.



HYDRAULIC HAND PALLET TRUCK

INSTRUCTION

Thank you for using our pallet truck. This pallet truck is made of high quality steel and is designed for the horizontal lifting and transport of loads on a pallet or standardized containers on a level, fixed base. **For your safety and correct operation, please carefully read this instruction before using it.**

NOTE: All of the information reported herein is based on data available at the moment of printing. We reserve the right to modify our own products at any moment without notice and incurring in any sanction. So, it is suggested to always verify possible updates.

1. GENERAL SPECIFICATIONS

Capacity	kg	2000	2500	3000	5000
Min. Fork Height	H(mm)	80	80	80	80
Max. Fork Height	H1(mm)	200	190-200	190-200	190-200
Max. Lifting Height	mm	110	110	110	110
Fork Width	B(mm)	550/685	550/685	550/685	685
Fork Length	L(mm)	1200	1200	1200	1200
Fork Size	mm	150x55	150x55	160x60	180x60
Tandem Loading Wheel	mm	Φ80x70	Φ80x70	Φ80x70	Φ80x67
Steering Wheel	mm	Φ180x50	Φ180x50	Φ180x50	Φ180x50
Material of Wheel	mm	Nylon/PU	Nylon/PU	Nylon/PU	Nylon
Net Weight	kg	68/70	73/75	78/80	140

Note: Materials and specification are subject to change without notice.

2. TO ATTACH DRAW-BAR TO PUMP UNIT

If you have purchased a wooden box of pallet truck, some assembly is required. Certainly, you need some tools, a hammer, a pliers, a spanner, etc; and some parts, one axle with hole (A105), two elastic pins (A106)(**Note one is in the axle A105**), these parts are putted in a plastic bag, which is putted into the draw-bar.

NOTE: The number of draw-bar and pump should be the same.

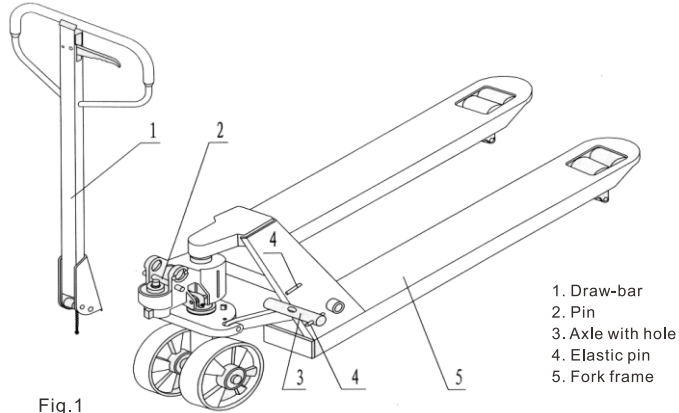

Fig.1

2.1 Insert the draw-bar onto the pump piston (A346), then use a hammer to insert the axle with hole (A105) into the hydraulic pump and draw-bar from the right to left. (See fig. 2).

2.2 Let control handle(A117) to the 'LOWER' position, then pass the adjusting nut(A104), adjusting bolt(A103) and chain(A102) through the hole of axle(A105) with your hand (See fig. 3).

2.3 Press the draw-bar (A110, A110B) down, take away the pin(#2) (See Fig. 1).

2.4 Let the control handle (A117) on 'RAISE' position, then raise the lever plate (A315) with the pin (#2) and insert the adjusting bolt(A103) into the front slot of lever plate (A315), note to keep the adjusting nut (A104) on the under side of the lever plate.

2.5 Use a hammer to tap another elastic pin (A106) into the axle with hole (A105).

The draw-bar is now assembled to the pump.

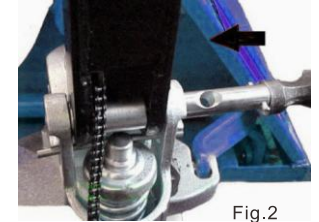

Fig.2

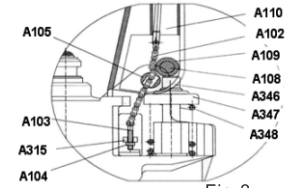

Fig.3

3. TO ADJUST RELEASE DEVICE

On the draw-bar of this pallet truck, you can find the control handle(A117) which can be regulated in three positions :

Raise -handle down

Drive position -handle in center position

Lower -handle up, the lever moves back the drive position when released.

If however they have been changed, you can adjust according to following step:

3.1 If the forks elevate while pumping in the **DRIVE** position, turn the adjusting nut (A104) on the adjusting bolt(A103) or screw(A318) clockwise until pumping action does not raise the forks and the **DRIVE** position functions properly.

3.2 If the forks descend while pumping in the **DRIVE** position, turn the nut(A104) or screw(A318) counter-clockwise until the forks do not lower.

3.3 If the forks do not descent when the control handle (A117) is in the **LOWER** position, turn the nut(A104) or screw (A318) clockwise until raising the control handle(A117) lowers the forks. Then check the **DRIVE** position according to item 3.1 and 3.2 to be sure the nut (A104) and screw(A318) is in the proper position.

3.4 If the forks do not elevate while pumping in the **RAISE** position, turn the nut (A104) or screw (A318) counter-clockwise until the forks elevate while pumping in the **RAISE** position. Then check the **LOWER** and **DRIVE** position according to item 3.1, 3.2 and item 3.3.

4. MAINTENANCE

The pallet truck is largely maintenance-free.

4.1 OIL

Please check the oil level every six months. The oil can be hydraulic oil: ISO VG32, its viscosity should be 30cSt at 400 C, total volume is about 0.4lt.

4.2 TO BANISH THE AIR

The air may come into the hydraulic oil because of transportation or pump in upset position. It can cause that the forks do not elevate while pumping in the **RAISE** position. The air can be removed in the following way: let the control handle (A117) on the **LOWER** position, then move the draw-bar up and down for several times.

4.3 DAILY CHECK AND MAINTENANCE

Daily check of the pallet truck can limit wear as much as possible. Special attention should be paid to the wheels, the axles, as thread, rags, etc. It may block the wheels. The forks should be unloaded and lowered in the lowest position

when the job is over.

4.4 LUBRICATION

All bearings and shafts are provided with long-life grease at the factory. You only need provide with long-life grease at monthly intervals or after each time the truck is cleaned thoroughly to the lubrication points.

5 GUIDE TO SAFETY OPERATION

- 5.1 Operator should read all warning signs and instructions here and on the pallet truck before using this truck.
- 5.2 Do not use on a slopping ground.
- 5.3 Do not operate a pallet truck unless you are familiar with it and have been trained or authorized to do so.
- 5.4 Do not operate a pallet truck unless you have checked its condition. Give special attention to the wheels or rollers, the draw-bar unit, the fork unit, the lever plate, etc. .
- 5.5 To pull the truck, always move the control handle into the drive position. This makes the draw-bar easier to move and depressurizes the pump section of the hydraulics. This preserves the hydraulic seals and the valve components. A long service life can be expected.
- 5.6 Do not take up any people on the pallet truck.
- 5.7 The operator had better take on gloves for labor protecting.
- 5.8 When the goods have been transported, all people should be away from the forks for 600mm.
- 5.9 Do not load goods like fig. 5/B .
- 5.10 Do not load over maximum capacity.
- 5.11 At others special condition or place, the operator should be carefully to operate the pallet truck.

6.TROUBLES SHOOTING

No.	Problem	Cause	Solution
1	The forks can not be up the max. height.	-The hydraulic oil is not enough.	-Pour in the oil.
2	The forks can not be lifted up.	-Without hydraulic oil. -The oil has impurities. -The nut (114) is too high, keep the pumping valve open. -Air come into the hydraulic oil.	-Fill in the oil. -Change the oil. -Adjust the nut(A104) or screw (A318) (see item 3.4) -Banish the air.(see item 4.2)
3	The forks can not be descended.	-The piston rod or pump body is deformed resulting from piston rod(246)or partial loading slanting to one side or over-loading. -The fork was kept in the high position for long time with piston rod bared to arise in rusting and jamming of the rod. -The adjusting nut (114)is not in correct position.	-Replace the piston rod (A344) or pump (A328). -Keeping the fork in the lowest position if not using, and pay more attention to lubricate the rod. -Adjust the nut (A104) or screw (A318) (see item 3.3)
4	Leaks	-Sealing parts worn or damaged. -Some part cracked or worn into small.	-Replace with the new one. -Replace with the new one.
5	The fork descends without the release valve worked.	-The impurities in the oil cause the release valve to be unable to close tight. -Some parts of hydraulic system is cracked or bored. -Air come into the oil. -Sealing parts worn or damaged. -The adjusting nut (A104) or screw (A318) is not in the correct position.	-Replace with new oil. -Inspect and replace the waste parts. -Banish the air. (See item 4.2) -Replace with the new one. -Adjusting the nut (A104) or screw (A318). (See item 3.2)

NOTE: DO NOT ATTEMPT TO REPAIR THE PALLET TRUCK UNLESS YOU ARE TRAINED AND AUTHORIZED TO DO SO.

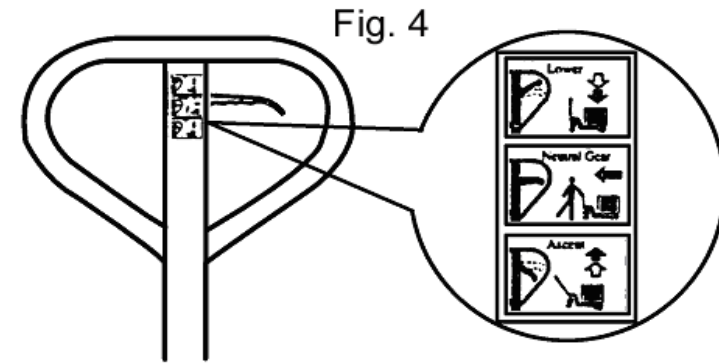
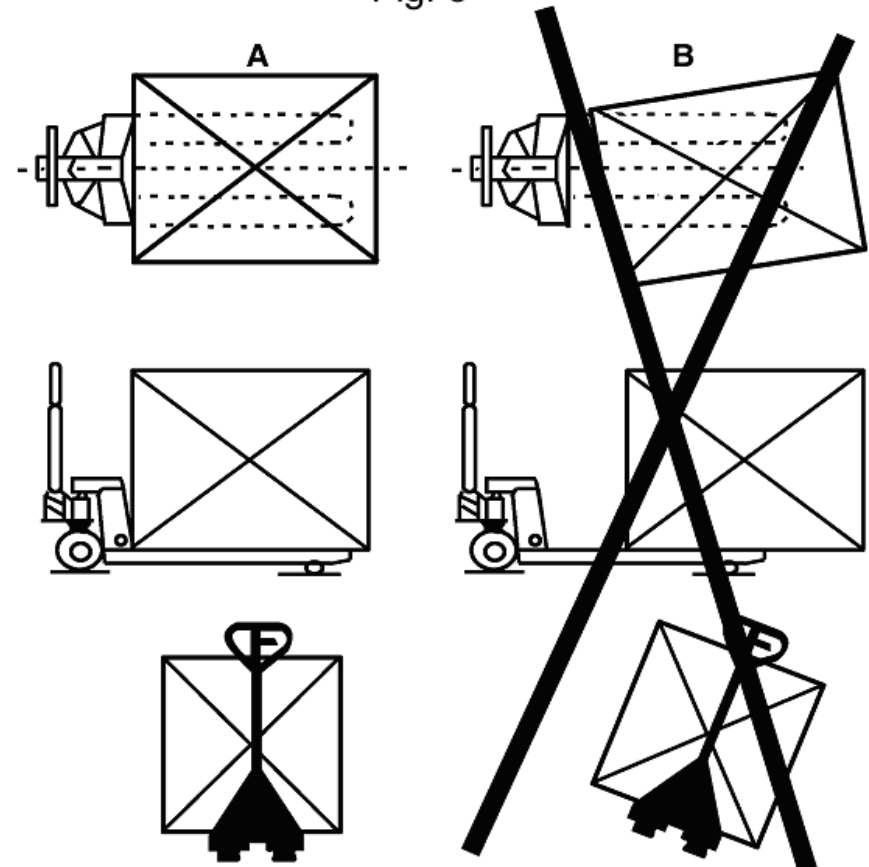
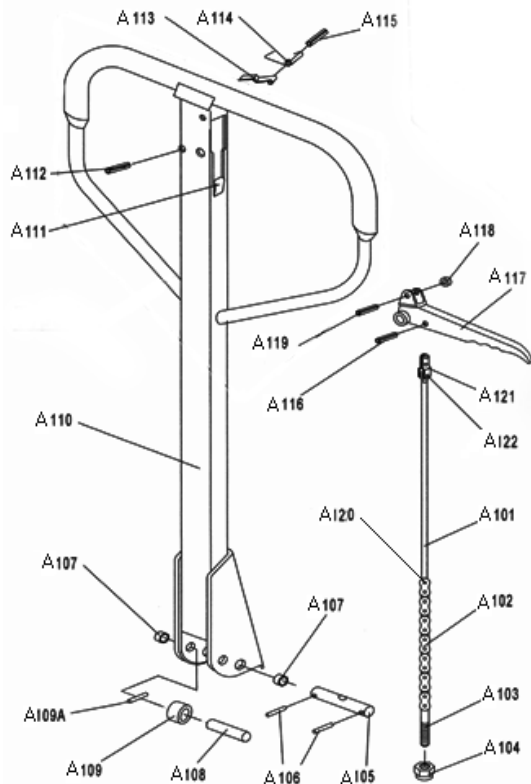

Fig. 5





LIST of DRAW-BAR

No.	Description	Qty.
A101	Release Rod	1
A102	Chain	1
A103	Adjusting Bolt	1
A104	Adjusting Nut	1
A105	Axle with Hole	1
A106	Elastic Pin	2
A107	Bushing	2
A108	Roller Pin	1
A109	Pressure Roller	1
A109A	Elastic Pin	1
A110	Draw-bar	1
A111	Stop Rubber	1
A112	Elastic Pin	1
A113	Blade Spring	1
A114	Spring	1
A115	Elastic Pin	1
A116	Elastic Pin	1
A117	Control Handle	1
A118	Roller	1
A119	Elastic Pin	1
A120	Pin	1
A121	Pull Board	1
A122	Pin	1

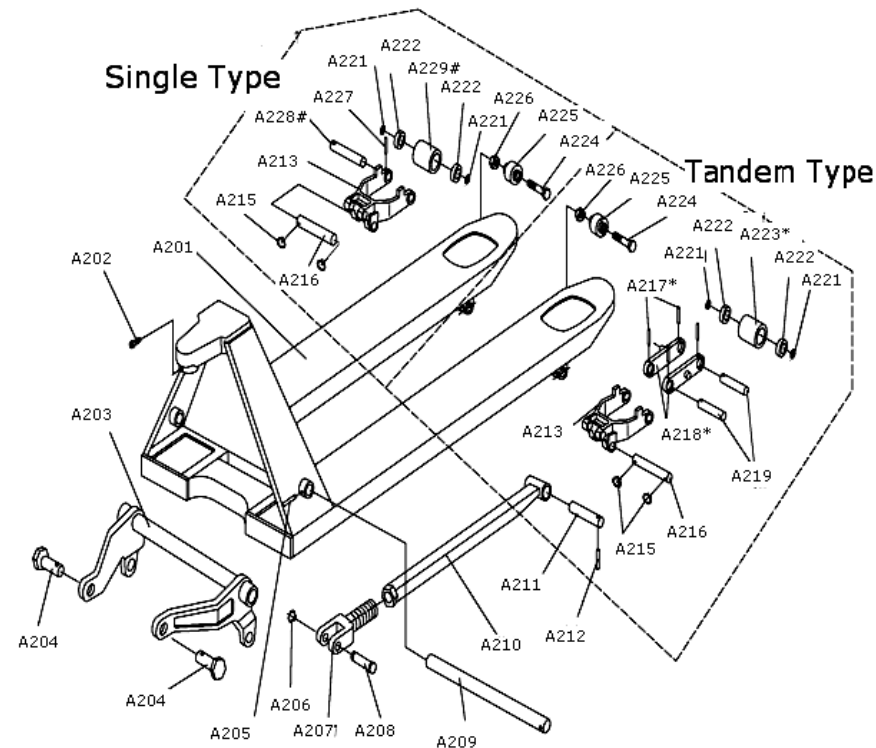

LIST OF FORK FRAME

No.	Description	Qty.	No.	Description	Qty.
A201	Fork Frame	1	A216	Shaft	2
A202	Bolt	1	A217*	Elastic Pin	4
A203	Rock-Arm	1	A218*	Linking Plate	4
A204	Shaft	2	A219	Shaft for Roller	1or4
A205	Pin	1	A221	Washer	8or4
A206	Retaining Ring	2	A222	Bearing	8or4
A207	Adjust Seat	2	A223*	Loading Roller	4
A208	Pin	2	A224	Bolt	2
A209	Shaft	1	A225	Enter Roller	2
A210	Pushing Rod	2	A226	Nut	8or2
A211	Shaft	2	A227	Elastic Pin	2
A212	Elastic Pin	2	A228#	Shaft for Roller	2
A213	Frame of Roller	2	A229#	Loading Roller	2
A215	Retaining Ring	2			

NOTE: *-- For double wheel,#-- For single wheel

Type A pump (Casting pump)

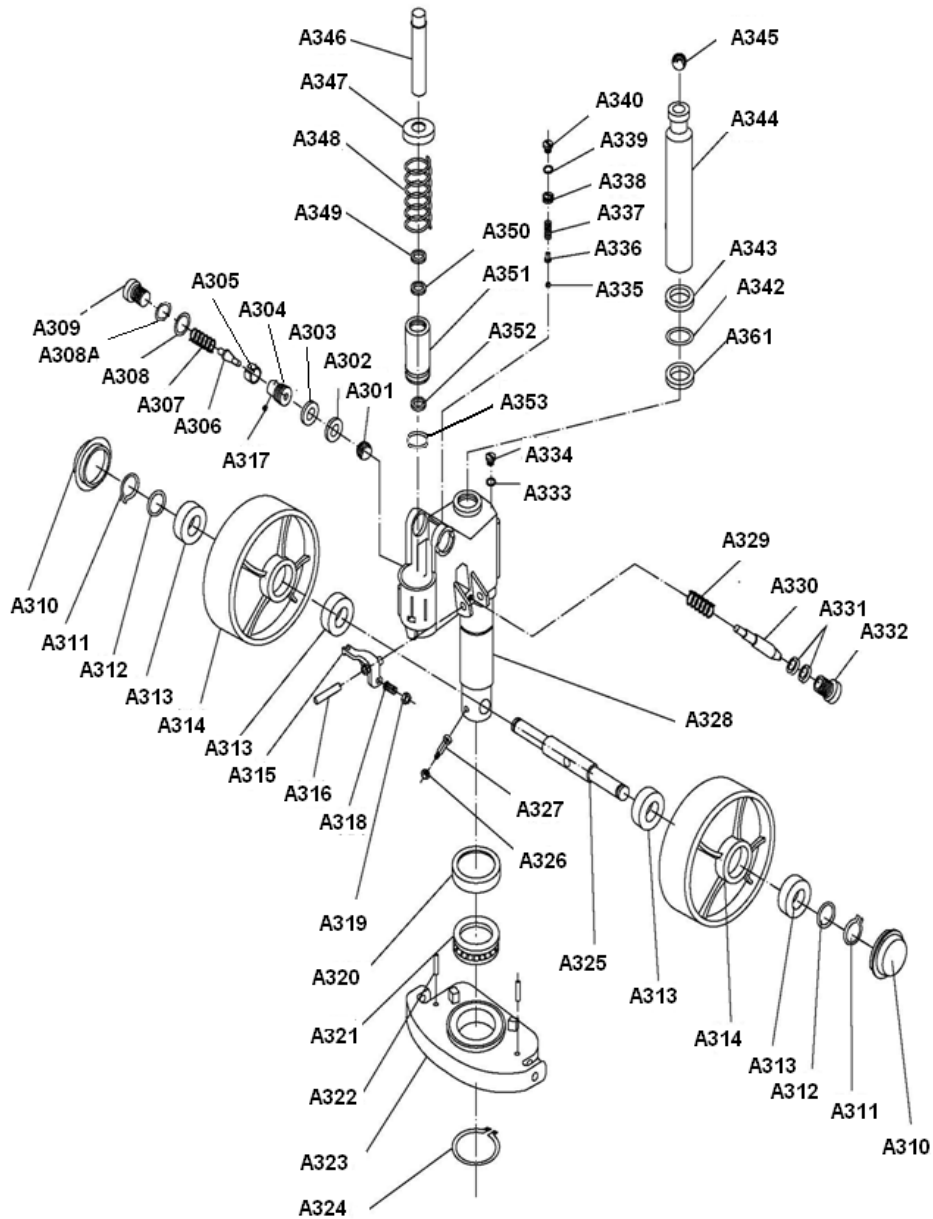

No.	Description	Quantity	No.	Description	Quantity
A301	Steel Ball	1	A327	Bolt	1
A302	Seal Washer	1	A328	Pump Body	1
A303	O-Ring	1	A329	Spring	1
A304	Seat of pumping valve	1	A330	Strike pin	1
A305	Sleeve	1	A331	O-Ring	1
A306	Spindle of pumping valve	1	A332	Axle Sleeve	1
A307	Spring	1	A333	Seal Washer	1
A308	O-Ring	1	A334	Screw Plug	1
A308A	Washer	1	A335	Steel Ball	1
A309	Screw	1	A336	Spindle of Safety Valve	1
A310	Dust Cover	1	A337	Spring	1
A311	Spring Washer	2	A338	Bolt	1
A312	Washer	2	A339	O-Ring	1
A313	Bearing	4	A340	Screw Plug	1
A314	Loading Wheel	2	A342	O-Ring	1
A315	Lever Plate	1	A343	Dust Ring	1
A316	Elastic Pin	1	A344	Piston Rod	1
A317	Elastic Pin	1	A345	Screw Ball	1
A318	Screw	1	A346	Pump Piston	1
A319	Nut	1	A347	Spring Cap	1
A320	Cover of Bearing	1	A348	Spring	1
A321	Bearing	1	A349	Dust Ring	1
A322	Elastic Pin	2	A350	Seal	1
A323	Thrust Plate	1	A351	Dust Cover	1
A324	Retaining Ring	1	A352	O-Ring	1
A325	Shaft of Loading Wheel	1	A353	Seal Washer	1
A326	Nut	1	A361	Seal	1

Type B pump (Welding pump)

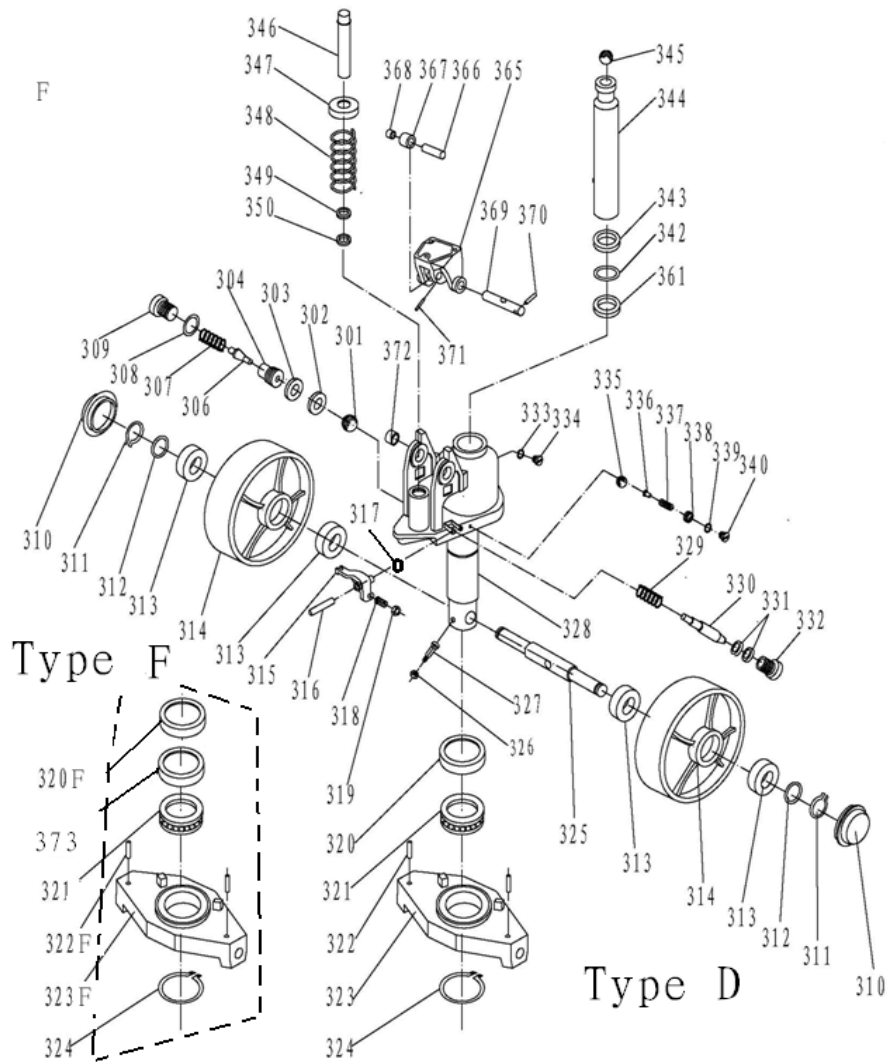

No.	Description	Quantity	No.	Description	Quantity
301	Steel Ball	1	330	Strike pin	1
302	Seal Washer	1	331	O-Ring	1
303	O-Ring	1	332	Axle Sleeve	1
304	Seat of pumping valve	1	333	Seal Washer	1
306	Spindle of pumping valve	1	334	Screw Plug	1
307	Spring	1	335	Steel Ball	1
308	O-Ring	1	336	Spindle of Safety Valve	1
309	Screw	1	337	Spring	1
310	Dust Cover	1	338	Bolt	1
311	Spring Washer	2	339	O-Ring	1
312	Washer	2	340	Screw Plug	1
313	Bearing	4	342	O-Ring	1
314	Loading Wheel	2	343	Dust Ring	1
315	Lever Plate	1	344	Piston Rod	1
316	Pin	1	345	Screw Ball	1
317	Spring Washe	1	346	Pump Piston	1
318	Screw	1	347	Spring Cap	1
319	Nut	1	348	Spring	1
320	Washer	1	349	Dust Ring	1
320F	Washer	1	350	Seal	1
321	Bearing	1	361	Seal	1
322	Elastic Pin	1	365	Bracket	1
322F	Elastic Pin	1	366	Shaft	1
323	Thrust Plate	1	367	Pressure Roller	1
323F	Thrust Plate	1	368	Bushing	1
324	Retaining Ring	1	369	Shaft	1
325	Shaft of Loading Wheel	1	370	Elastic Pin	1
326	Nut	1	371	Elastic Pin	1
327	Bolt	1	372	Bushing	2
328	Pump Body	1	373	Cover of Bearing	1
329	Spring	1			