

***Titansuhe***

**Operating Instructions  
Parts List**

**SYC Series Hand Stacker**



**Note: Owner and operator MUST read and understand this operating instructions before use this pallet truck.**

Welcome to use our hand stacker SYC series. This stacker is made of high quality steel and was designed to give a durable, reliable and easy to use product. For your safety and correct operation, please carefully read this instruction book and warnings on the stacker before using it.

**NOTE: All of the information reported herein is based on data available at the moment of printing. The factory reserves the right to modify its own products at any moment without notice and incurring in any sanction. So, it is suggested to always verify possible updates.**

## 1. STRUCTURAL DATA FORM

Model		SYC1016	SYC1516	SYC2016	SYC1020/25/ 30	SYC1520/25/ 30
Capacity	Kg	1000	1500	2000	1000	1500
Lift Height	mm	1600	1600	1600	2000/2500/ 3000	2000/2500/ 3000
Fork Length	mm	900/1000/1150	900/1000/1150	900/1000/1150	900/1000/1150	900/1000/1150
Width overall Forks	mm	320-740/550	320-740/550	320-740/550	320-740/550	320-740/550
Overall Height	mm	2060	2060	2060	2060	2060
Min. Fork Height	mm	85	85	85	85	85

## 2. Installation & Adjustment

\*To prevent oil-leaking from oil tank during transportation. Air Screw (part No.F249) is replaced with oil-sealing screw in the factory but it has to be replaced back when you put this stacker in use.

\*How to change: screw out oil-sealing Screw, then screw in Air Screw which is in the spare parts bag, thus keep oil tank always connecting with atmosphere.

## 3. SAFETY GUIDANCE

- 3.1 Operator should read all warning signs and instructions here and on the stacker before using it.
- 3.2 Do not operate a hand stacker unless you are familiar with it and have been trained or authorized to do so.
- 3.3 Do not operate a hand stacker unless you have checked its condition. Give special attention to the wheels, the handle, the guide frame, the pilot wheel, the doorframe, etc.
- 3.4 Do not use it on a slopping ground.
- 3.5 Do not take up any people on the forks.
- 3.6 The operator had better take on gloves for labor protecting.
- 3.7 When the goods have been transported or lifted, all people should be away form the

forks for 600mm.

3.8 Do not load over maximum capacity.

3.9 The weight of goods should be distributed on the two forks, do not use only one fork.  
The center of gravity of goods should be in the center of two forks.

3.10 People forbid standing under the forks.

3.11 Do not move the hand stacker when the goods are lifted to the height more than 300mm.

3.12 At other special condition or place, the operator should be carefully to operate the hand stacker.

## 4. MAINTENANCE

### 4.1 Hydraulic oil

Please check the oil level every six months. The oil can be hydraulic oil: **ISO VG32**, its viscosity should be 32cSt at 40°C, total volume is about 2.0lt.

### 4.2 Daily check and maintenance

It is necessary to check the hand stacker daily. Special attention should be paid to the wheels, the axles, as thread, rags, etc., it may block the wheels, the fork and the mast should be checked, too. The forks should be unloaded and lowered in the lowest position when the job is over.

### 4.3 Lubrication

Use motor oil or grease to lubricate all movable parts.

### 4.4 Remove the air

The air may enter the hydraulic pump during the transportation after the customer buys it. It will cause the piston rod to fail to keep up the raised height. The air can be removed in the following way: pull the control handle (FS107) up and move handle (FS110) up and down for several times.

## 5. TO ADJUST RELEASE DEVICE

On the draw-bar of this hand stacker, you can find the control handle (FS107) which can be regulated in three positions: **LOWER** = to lower the forks; **NEUTRAL** = to move the load, and **LIFT** = to raise the fork. These three positions have been pre-positied at the factory. If however they have been changed, you can adjust according to following step:

4.1 If the forks elevate while pumping in the **NEUTRAL** position, turn the adjusting nut (FS116) on the adjusting bolt (FS115) clockwise or turn the adjusting screw (F229) clockwise until pumping action does not raise the forks and the **NEUTRAL** position functions properly.

4.2 If the forks descend while pumping in the **NEUTRAL** position, turn the nut (FS116) or the screw (F229) counter-clockwise until the forks do not lower.

4.3 If the forks do not descent when the control handle (FS107) is in the **LOWER** position, turn the nut (FS116) or the screw (F229) clockwise until raising the control handle (FS107) lowers the forks. Then check the **NEUTRAL** position according to item 4.1 and 4.2 to be sure the nut (FS116) and the screw (F229) is in the proper position.

4.4 If the forks do not elevate while pumping in the **LIFT** position, turn the nut (FS116) or the screw (F229) counter-clockwise until the forks elevate while pumping in the **LIFT** position. Then check the **LOWER** and **NEUTRAL** position according to item 4.1, 4.2 and 4.3.

## 6. TROUBLES SHOOTING

No	Trouble	Clause	Fixing Methods
1	The forks can not be up the max. height.	- The hydraulic oil is not enough.	- Pour in the oil.
2	The forks can not be lifted up.	- Without hydraulic oil. - The oil has impurities. - The nut (FS116) is too high or the screw (F229) is too close, keep the pumping valve open. - Air comes into the hydraulic oil.	- Fill in the oil. - Change the oil. - Adjust the nut (FS116) or the screw (F229) .(see item 4.4)  - Banish the air.(see item 3.4)
3	The forks can not be descended.	- The piston rod(F248) or pump body(F225) or the mast (F346) is deformed resulting from loading slanting to one side or over-loading. - The fork was kept in the high position for long time with piston rod bared to arise in rusting and jamming of the rod. - The adjusting nut (FS116) or the screw (F229) is not in the correct position. - The rollers (F327) are not lubricated.	- Replace it.  - Keeping the fork in the lowest position if not using, and pay more attention to lubricate the rod.  - Adjust the nut (FS116) or the screw (F229). (see item 4.3) - Lubricate its.
4	Leaks	- Sealing parts worn or damaged. - Some part cracked or worn into small.	- Replace with the new one.  - Replace with the new one.
5	The fork descends without the release valve worked.	- The impurities in the oil cause the release valve to be unable to close tight. - Some parts of hydraulic system is cracked or bored. - Air comes into the oil. - Sealing parts worn or damaged. - The adjusting nut (FS116) or the screw (F229) is not in the correct position.	- Replace with new oil.  - Inspect and replace the waste parts. -Banish the air. (See item 3.4) - Replace with the new one.  - Adjusting the nut (FS116) or the screw (F229). (See item 4.2)

**NOTE: DO NOT ATTEMP TO REPAIR THE PALLET TRUCK UNLESS YOU ARE TRAINED AND AUTHORIZED TO DO SO.**

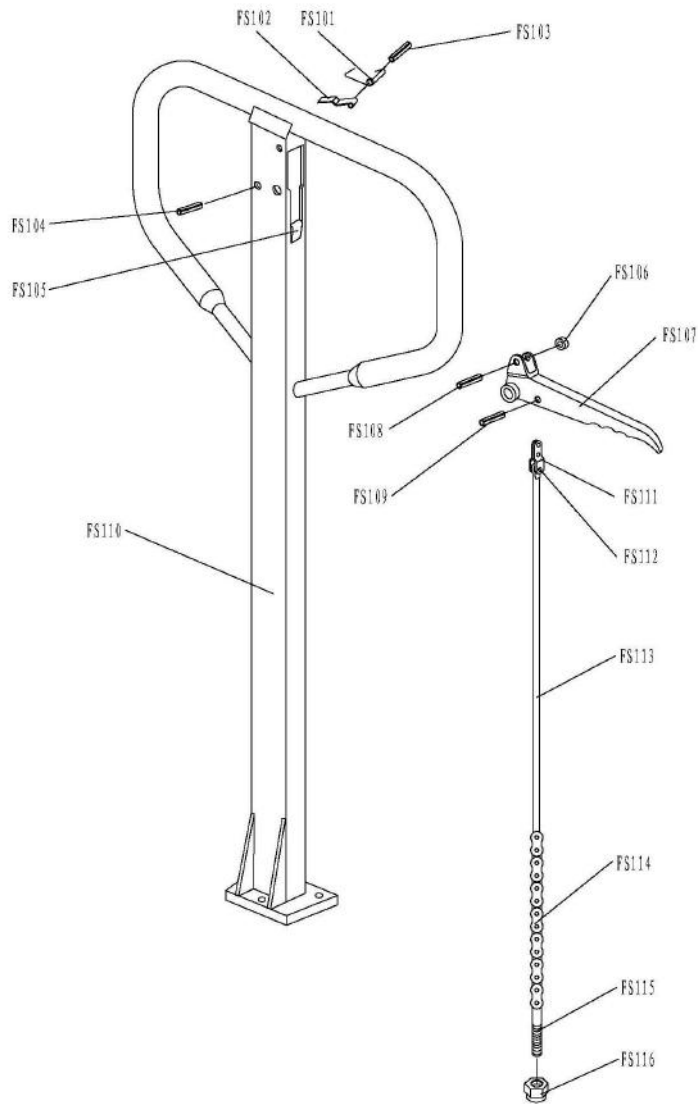

### Handle Part List

No.	Description	Qty.	No.	Description	Qty.
FS101	Spring	1	FS109	Elastic Pin	1
FS102	Bldae Spring	1	FS110	Handle	1
FS103	Elastic Pin	1	FS111	Pull Board	1
FS104	Elastic Pin	1	FS112	Pin	1
FS105	Rubber Washer	1	FS113	Release Rod	1
FS106	Roller	1	FS114	Chain	1
FS107	Control Handle	1	FS115	Adjusting Bolt	1
FS108	Elastic Pin	1	FS116	Adjusting Nut	1

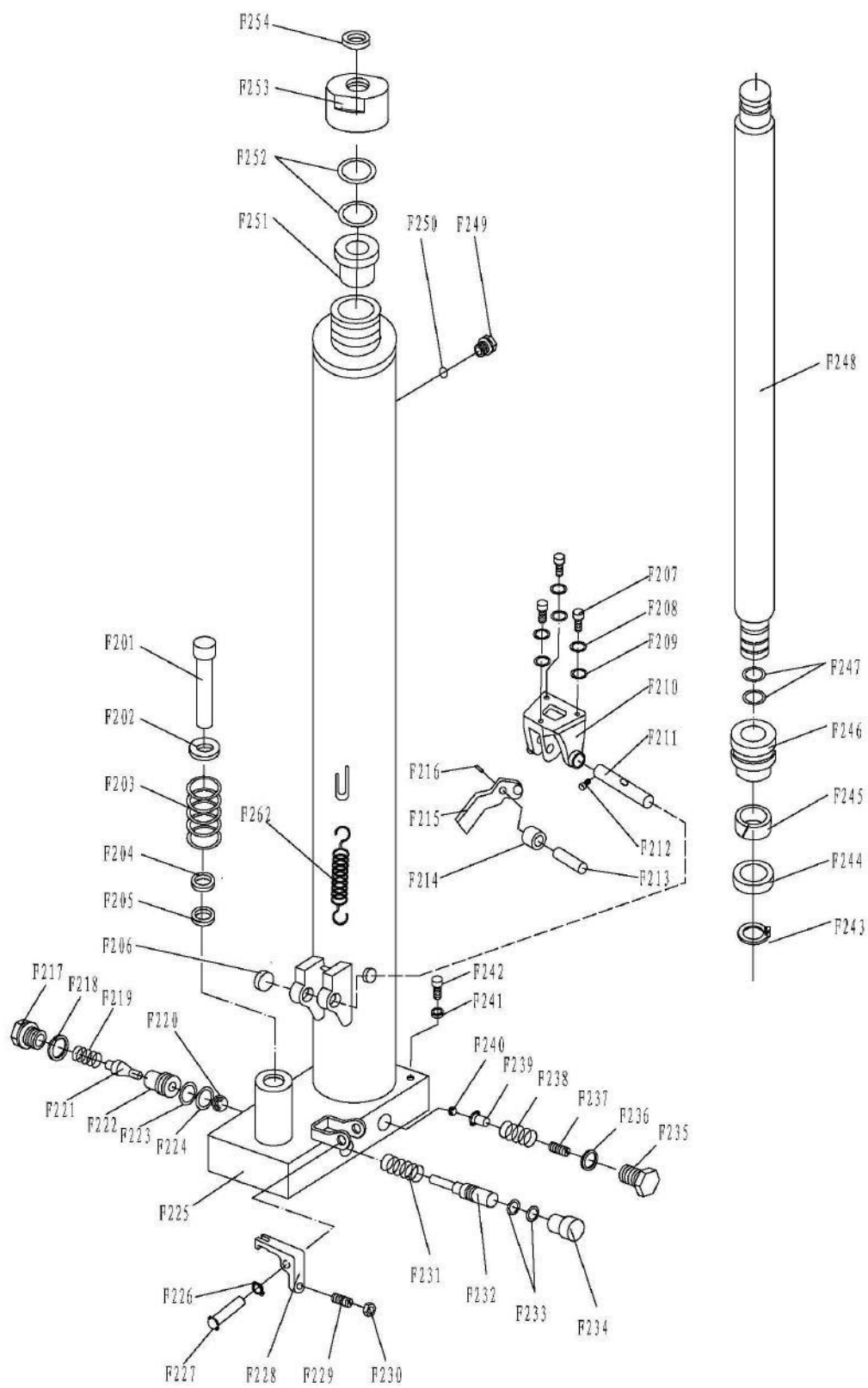

**Pump Part List for SYC1016;1516;2016;1025;1030;**

<b>No.</b>	<b>Description</b>	<b>Qty.</b>	<b>No.</b>	<b>Description</b>	<b>Qty.</b>
F201	Pump Piston Rod	1	F229	Screw	1
F202	Spring Washer	1	F230	Nut	1
F203	Spring	1	F231	Spring	1
F204	Dust Ring	1	F232	Strike Pin	1
F205	Seal	1	F233	O-Ring	2
F206	Bushing	2	F234	Dust Catcher	1
F207	Screw	3	F235	Cover with Screw	1
F208	Washer	3	F236	Seal Washer	1
F209	Spring Washer	3	F237	Adjusting Bolt	1
F210	Bracket	1	F238	Spring	1
F211	Shaft for Roller	1	F239	Spring Seat	1
F212	Screw	1	F240	Steel Ball	1
F213	Shaft	1	F241	Seal Washer	1
F214	Pressure Roller	1	F242	Screw	1
F215	Lever of Pedal	1	F243	Locking Ring	1
F216	Elastic Pin	1	F244	Y-Ring	1
F217	Screw	1	F245	Support Ring	1
F218	Seal Washer	1	F246	Piston	1
F219	Spring	1	F247	O-Ring	2
F220	Steel Ball	1	F248	Lifting Piston Rod	1
F221	Valve Spindle of Pump	1	F249	Screw	1
F222	Seat of pump Valve	1	F250	Screw	1
F223	O-Ring	1	F251	Conduit	1
F224	Washer	1	F252	O-Ring	2
F225	Body of Pump	1	F253	Cover with Screw	1
F226	Locking Ring	1	F254	Dust Ring	1
F227	Elastic Pin	1	F262	Spring	2
F228	Lever Plate	1			

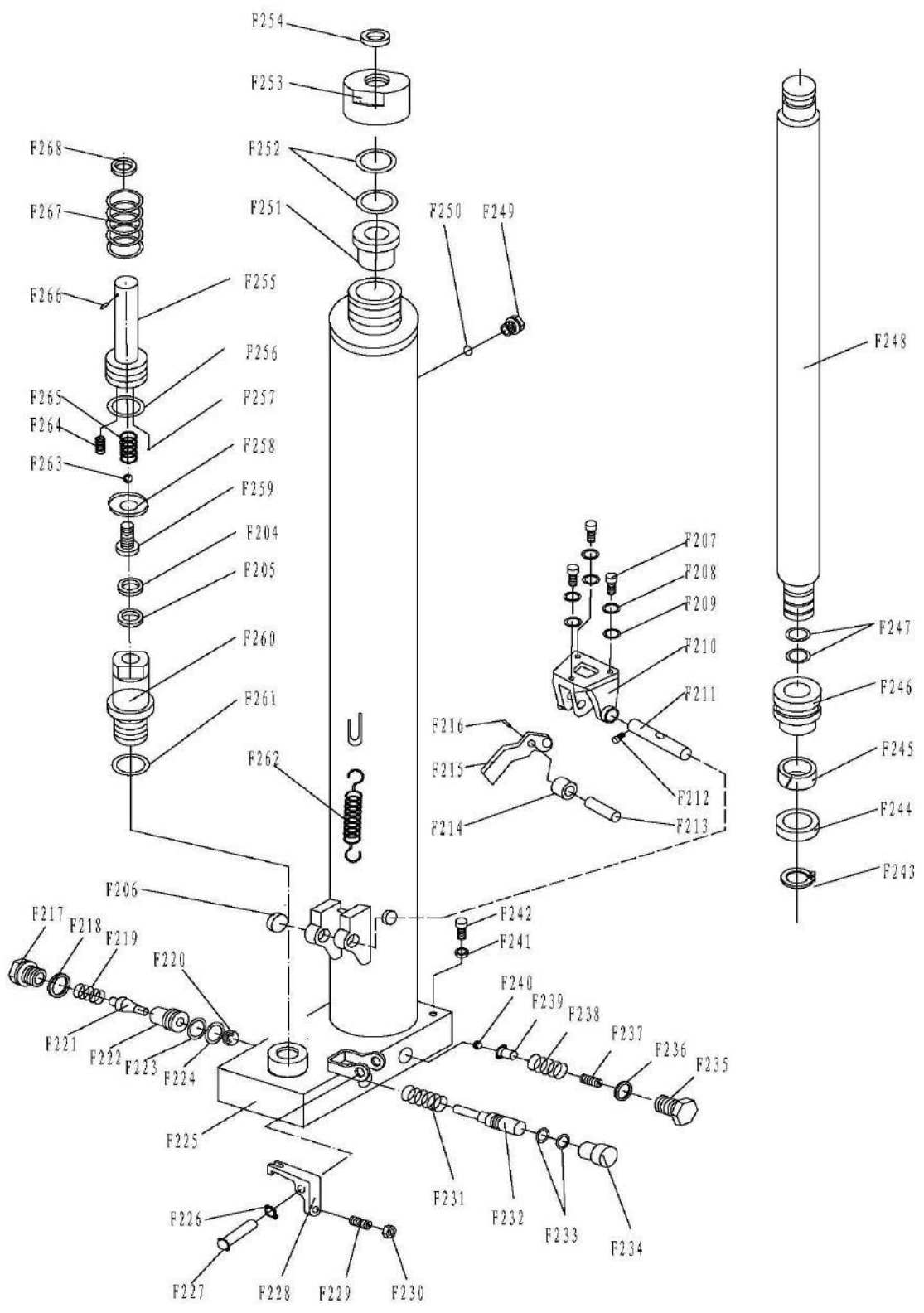



## Pump Part List for SYC1016;1516;1025;1030; Fast Lifting

No.	Description	Qty.	No.	Description	Qty.
F201	Pump Piston Rod	1	F235	Cover with Screw	1
F202	Spring Washer	1	F236	Seal Washer	1
F203	Spring	1	F237	Adjusting Bolt	1
F204	Dust Ring	1	F238	Spring	1
F205	Seal	1	F239	Spring Seat	1
F206	Bushing	2	F240	Steel Ball	1
F207	Screw	3	F241	Seal Washer	1
F208	Washer	3	F242	Screw	1
F209	Spring Washer	3	F243	Locking Ring	1
F210	Bracket	1	F244	Y-Ring	1
F211	Shaft for Roller	1	F245	Support Ring	1
F212	Screw	1	F246	Piston	1
F213	Shaft	1	F247	O-Ring	2
F214	Pressure Roller	1	F248	Lifting Piston Rod	1
F215	Lever of Pedal	1	F249	Screw	1
F216	Elastic Pin	1	F250	Screw	1
F217	Screw	1	F251	Conduit	1
F218	Seal Washer	1	F252	O-Ring	2
F219	Spring	1	F253	Cover with Screw	1
F220	Steel Ball	1	F254	Dust Ring	1
F221	Valve Spindle of Pump	1	F255	Pump Piston Rod	1
F222	Seat of pump Valve	1	F256	O-Ring	1
F223	O-Ring	1	F257	Steel Ball	2
F224	Washer	1	F258	Washer	1
F225	Body of Pump	1	F259	Screw	1
F226	Locking Ring	1	F260	Pumping Cylinder	1
F227	Elastic Pin	1	F261	Seal Washer	1
F228	Lever Plate	1	F262	Spring	2
F229	Screw	1	F263	Steel Ball	1
F230	Nut	1	F264	Spring	2
F231	Spring	1	F265	Spring	1
F232	Strike Pin	1	F266	Pin	1
F233	O-Ring	2	F267	Spring	1
F234	Dust Catcher	1	F268	Cap of Spring	1

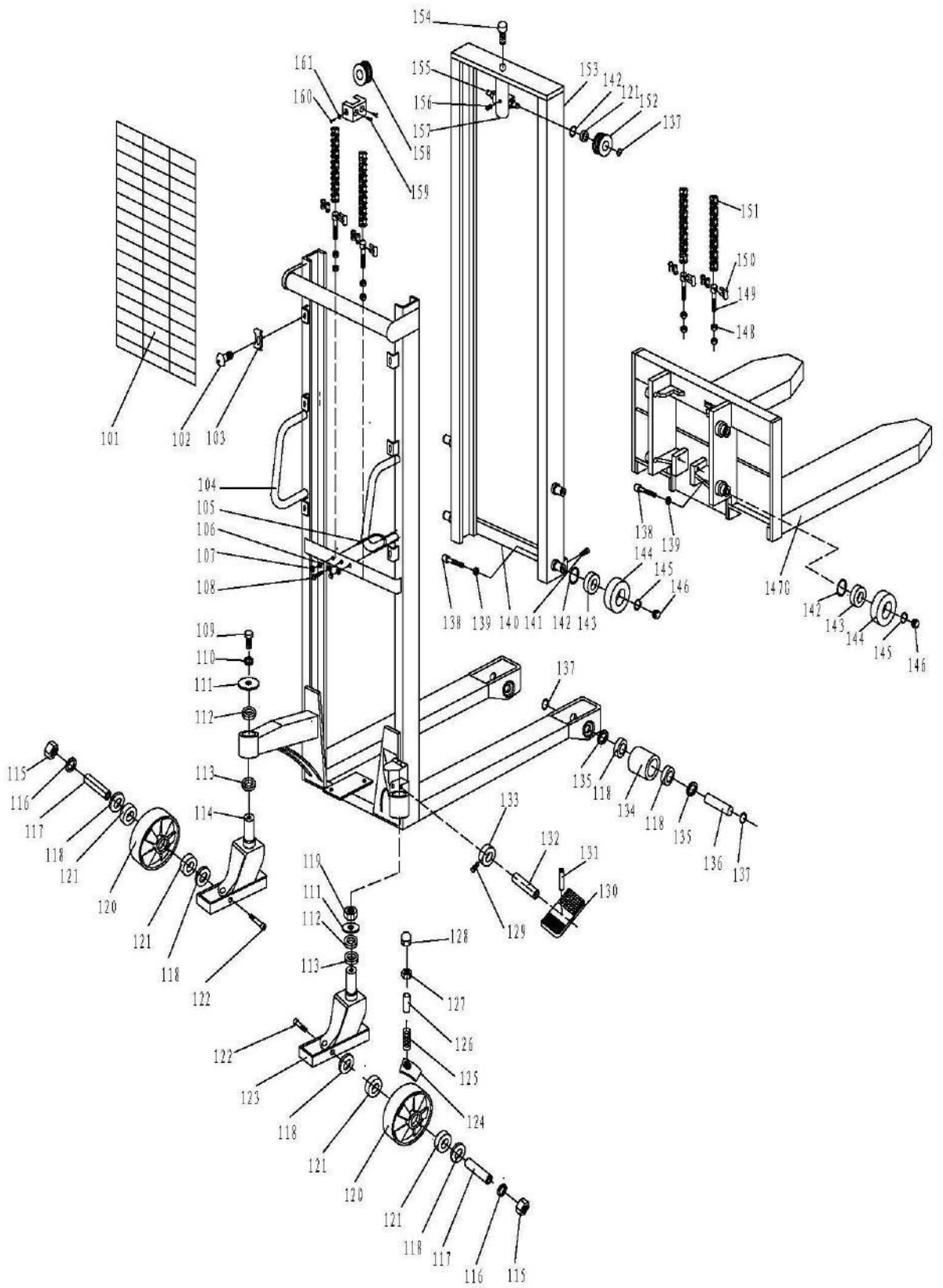

**Mast Part List for SYC1025;1030;**

<b>No.</b>	<b>Description</b>	<b>Qty.</b>	<b>No.</b>	<b>Description</b>	<b>Qty.</b>
101	Reticulation	1	132	Shaft	1
102	Screw	6	133	Cam	1
103	Clip	6	134	Washer	4
104G	Mast	1	135	Shaft of Roller	2
105	Hoop	1	136	Roller	2
106	Nut	3	137	Locking Ring for Axle	14
107	Nut	2	138	Screw	8
108	Bolt	1	139	Nut	8
109	Bolt	1	140	Linking Plate	1
110	Elastic Washer	1	141	Screw	4
111	Washer	1	142	Locking Ring for Hole	4
112	Bearing	2	143	Bearing	8
113	Bearing	2	144	Roller	4
114	Frame of Wheel	1	145	Locking Ring	8
115	Nut	2	146	Steel Ball	8
116	Elastic Washer	2	147G	Fixed Fork	4
117	Axle	2	148	Nut	4
118	Washer	8	149	Bolt	2
119	Nut	1	150	Connect	2
120	Wheel	2	151	Chain	2
121	Bearing	8	152	Roller for Chain	2
122	Screw	2	153	Inner Mast	1
123	Frame of Wheel with	1	154	Screw	4
124	Brake Plate	1	155	Axle	4
125	Spring	1	156	Elastic Pin	1
126	Cover	1	157	Frame	4
127	Nut	1	158	Wheel	2
128	Nut	1	159	Bolt	4
129	Screw	1	160	Axle	2
130	Pedal	1	161	Locking Ring for Hole	2
131	Elastic Pin	1			

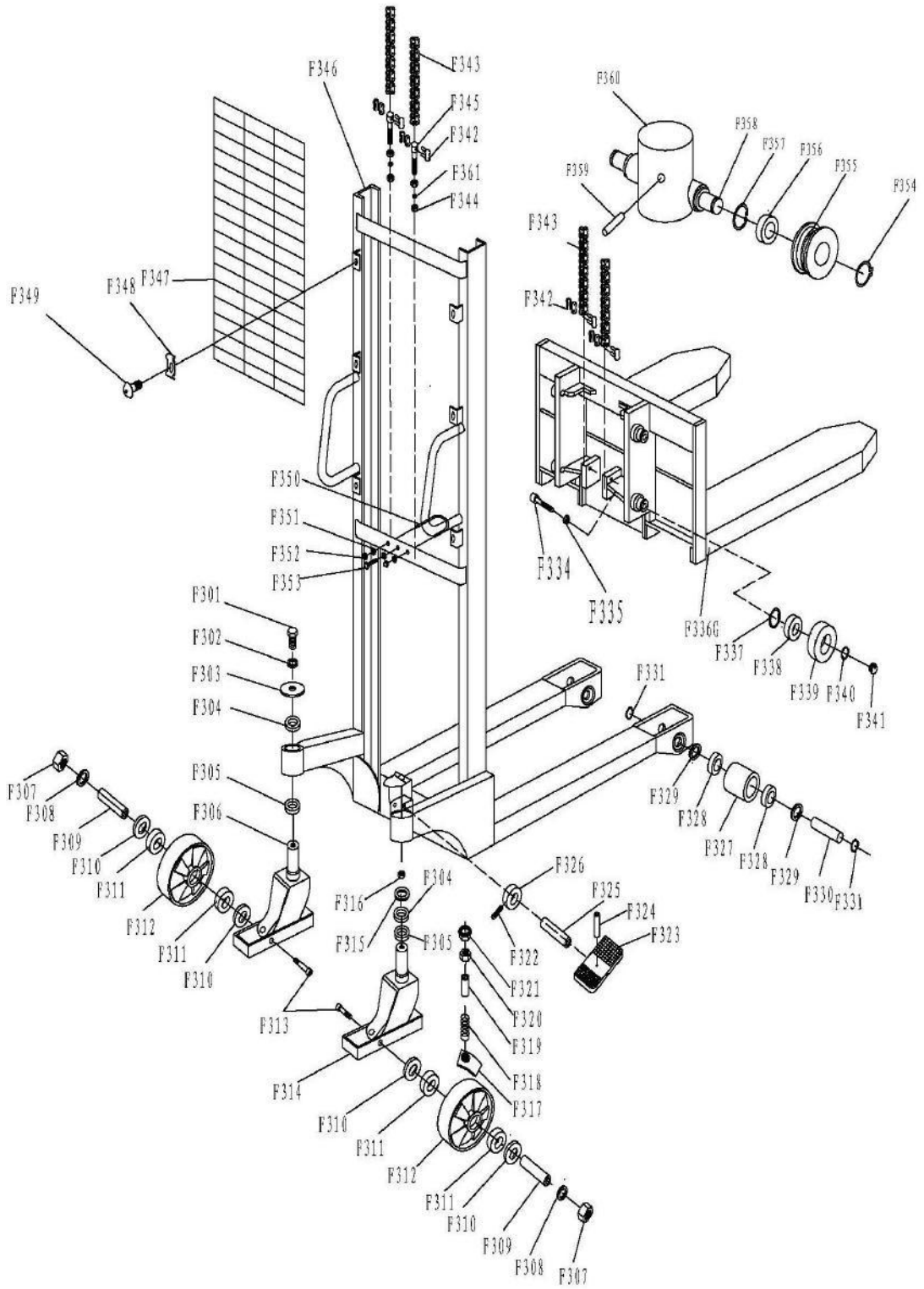

## Mast Part List for SYC1016;1516;2016;

No.	Description	Qty.	No.	Description	Qty.
F301	Bolt	1	F331	Locking Ring	4
F302	Elastic Washer	1	F334	Bolt	4
F303	Washer	1	F335	Nut	4
F304	Bearing	2	F336	Fork	2
F305	Bearing	2	F337	Locking Ring	4
F306	Frame of Wheel	1	F338	Bearing	4
F307	Nut	2	F339	Roller	4
F308	Elastic Washer	2	F340	Locking Ring	4
F309	Axle of Wheel	2	F341	Steel Ball	4
F310	Cover	4	F342	Connect	2
F311	Bearing	4	F343	Chain	2
F312	Wheel	2	F344	Nut	2
F313	Screw	2	F345	Bolt	1
F314	Frame of Wheel With Brake	1	F346	Mast	1
F315	Washer	1	F347	Reticulation	1
F316	Nut	1	F348	Clip	6
F317	Brake Plate	1	F349	Screw	6
F318	Spring	1	F350	Hoop to Holding Pump	1
F319	Cover	1	F351	Nut	3
F320	Nut	1	F352	Nut	2
F321	Nut	1	F353	Bolt	1
F322	Screw	1	F354	Locking Ring	2
F323	Footplate	1	F355	Roller for Chain	2
F324	Elastic Pin	1	F356	Bearing	2
F325	Pin	1	F357	Locking Ring	2
F326	Cam	1	F358	Axle	1
F327	Roller	2	F359	Elastic Pin	1
F328	Bearing	4	F360	Frame	1
F329	Cover	4	F361	Elastic Washer	3
F330	Axle of Loading Roller	2			

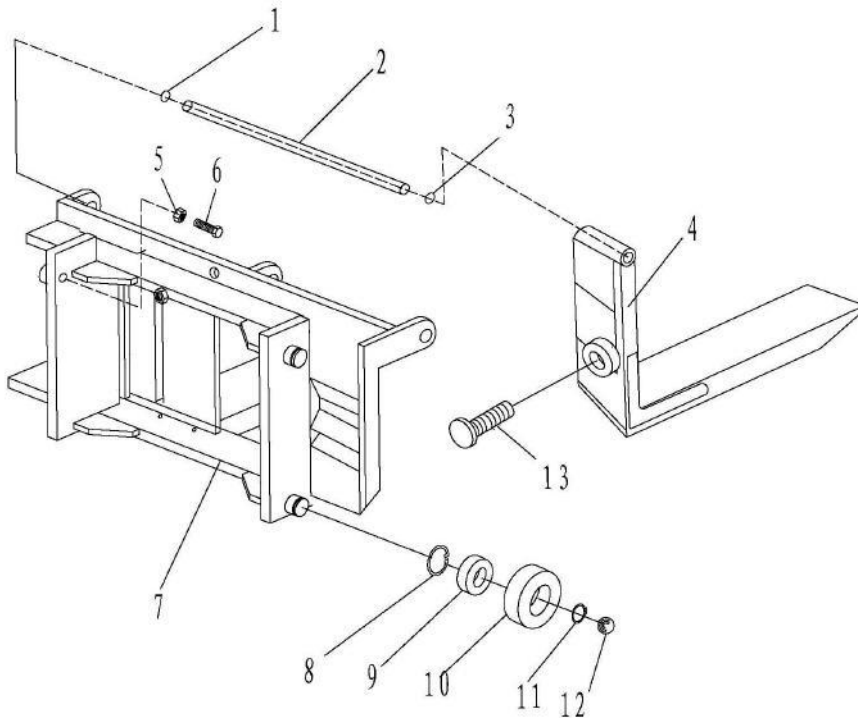

### ADJUSTED FORK LIST

No.	Description	Qty.
1	Locking Ring	1
2	Long Axle	1
3	Locking Ring	1
4	Adjusting Fork	2
5	Nut	4
6	Bolt	4
7	Frame Carriage	1
8	Locking Ring for Hole	4
9	Bearing	4
10	Roller	4
11	Locking Ring	4
12	Steel Ball	4
13	Bolt	2