



CHONGQING TITAN SUHE TECH CO., LTD  
Address: 8-3, A Tower, Xiexin Building, Hongjin Road,  
Yubei District, Chongqing, China

Tel: 0086-23-67109118  
Fax: 0086-23-67109618

What's app/wechat : +8617815375169  
Email: sales101@titansuhe.com

**WWW.TITANSUHELIFT.COM**

**HSZ-A636 Series Manual Chain Block Specifications**



- 360° free pulling
- G80 alloy steel load chain with black oxide finish for rust resistance
- Zinc plated hand chain always keeps your hands clean
- Large throat opening hook
- Quenched and tempered gear set provide high strength and durable wear resistance
- Automatic double pawl brake system offers double safety
- Industrial grade powder painting meet RoHS requirement
- Captured bearing type side plate
- Type tested with mini. 4 times safety factor and 1500 cycles life test
- Meet EN13157 and ANSIB30.6, AS1418 Specifications.

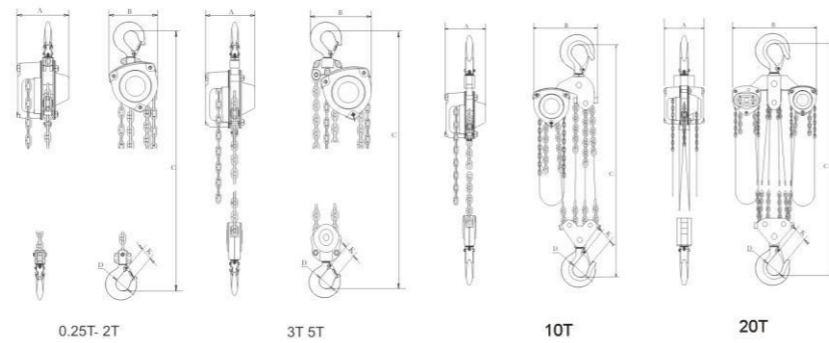

| Model                                |      | HSZ-0.25 | HSZ-0.5    | HSZ-1    | HSZ-1.5    | HSZ-2      | HSZ-3    | HSZ-5    | HSZ-10   | HSZ-20   |
|--------------------------------------|------|----------|------------|----------|------------|------------|----------|----------|----------|----------|
| Capacity                             | tons | 0.25     | 0.5        | 1        | 1.5        | 2          | 3        | 5        | 10       | 20       |
| Standard lift                        | m    | 2.5      | 2.5        | 2.5      | 2.5        | 3          | 3        | 3        | 3        | 3        |
| Proof test load                      | kN   | 3.75     | 7.5        | 15       | 22.5       | 30         | 45       | 75       | 150      | 300      |
| Effort required to lift rated load   | N    | 186      | 200        | 295      | 305        | 320        | 310      | 365      | 380      | 380      |
| Diameter of load chain               | MM   | 4x12     | 5x15       | 6x18     | 8x24       | 8x24       | 8x24     | 10x30    | 10x30    | 10x30    |
| Strands of load chain                |      | 1        | 1          | 1        | 1          | 1          | 2        | 2        | 4        | 8        |
| Dimensions                           | A    | 105      | 144        | 153      | 160        | 167        | 160      | 195      | 195      | 195      |
|                                      | B    | 109      | 145        | 155      | 185        | 194        | 205      | 250      | 365      | 632      |
|                                      | C    | 250      | 350        | 385      | 420        | 470        | 555      | 695      | 815      | 890      |
|                                      | D    | 32       | 35         | 44       | 50         | 52         | 59       | 69       | 91       | 110      |
|                                      | K    | 27       | 24         | 28       | 32         | 34         | 39       | 46       | 62       | 85       |
| Net weight                           | kg   | 3.9      | 9.6        | 11       | 15.5       | 16.2       | 25       | 37       | 67       | 153      |
| Packing measurement                  | cm   | 25x19x18 | 24.5x19x18 | 26x19x19 | 30.5x21x19 | 30x23.5x23 | 34x24x19 | 49x29x23 | 47x42x22 | 80x70x23 |
| Extra weight per meter of extra lift | kg   | 0.37     | 1.3        | 1.6      | 2.3        | 2.3        | 3.6      | 5.3      | 9.4      | 19.3     |

**HSH-A636 Series Lever Block Specifications**

- Reinforced lever handle
- Casting hand wheel
- G80 alloy steel load chain with black oxide finish for rust resistance
- Quenched and tempered gear set provide high strength and durable wear resistance
- Automatic double pawl brake system offers double safety
- Industrial grade powder painting meet RoHS requirement
- Type tested with mini. 4 times safety factor and 1500 cycles life test
- Meet EN13157, ANSIB30.6, AS1418 Specifications.

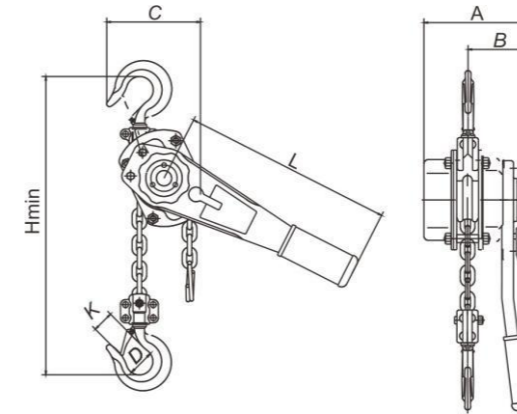

| Model                                |            | HSH636-0.75 | HSH636-1   | HSH636-1.5 | HSH636-2 | HSH636-3     | HSH636-6 | HSH636-9 |
|--------------------------------------|------------|-------------|------------|------------|----------|--------------|----------|----------|
| Capacity                             | tons       | 0.75        | 1          | 1.5        | 2        | 3            | 6        | 9        |
| Standard lift                        | m          | 1.5         | 1.5        | 1.5        | 1.5      | 1.5          | 1.5      | 1.5      |
| Running test load                    | kN         | 11.2        | 15         | 22.5       | 30       | 45           | 75       | 135      |
| Effort required to lift rated load   | N          | 140         | 185        | 220        | 250      | 320          | 340      | 360      |
| Diameter of load chain               | MM         | 6x18        | 6x18       | 8x24       | 8x24     | 10x30        | 10x30    | 10x30    |
| Strands of load chain                |            | 1           | 1          | 1          | 1        | 1            | 2        | 3        |
| Dimensions                           | A          | 148         | 145        | 184        | 175      | 195          | 190      | 195      |
|                                      | B          | 90          | 86         | 112        | 100      | 115          | 115      | 115      |
|                                      | C          | 115         | 134        | 135        | 150      | 145          | 242      | 307      |
|                                      | H          | 370         | 315        | 435        | 380      | 560          | 650      | 700      |
|                                      | L          | 310         | 285        | 415        | 410      | 415          | 415      | 415      |
|                                      | K          | 27          | 33         | 32         | 41       | 46           | 45.6     | 71       |
|                                      | Net weight | kg          | 6.7        | 5.5        | 11.4     | 9.5          | 18.8     | 27.8     |
| Packing measurement                  | cm         | 37.5x16x18  | 37.5x16x18 | 52x17x22   | 52x17x22 | 55x18.5x22.5 | 57x21x23 | 60x42x28 |
| Extra weight per meter of extra lift | kg         | 0.8         | 0.8        | 1.4        | 1.4      | 2.2          | 4.4      | 6.6      |