



CHONGQING TITAN SUHE TECH CO., LTD
Address: 8-3, A Tower, Xiexin Building, Hongjin Road,
Yubei District, Chongqing, China

Tel: 0086-23-67109118
Fax: 0086-23-67109618

What's app/wechat : +8617815375169
Email: sales101@titansuhe.com

WWW.TITANSUHELIFT.COM

HSZ-A620 Series Manual Chain Block Specifications



- G80 alloy steel load chain with black oxide finish for rust resistance
- Zinc plated hand chain always keeps your hands clean
- Quenched and tempered gear set provide high strength and durable wear resistance
- Automatic double pawl brake system offers double safety
- Industrial grade powder painting meet RoHS requirement

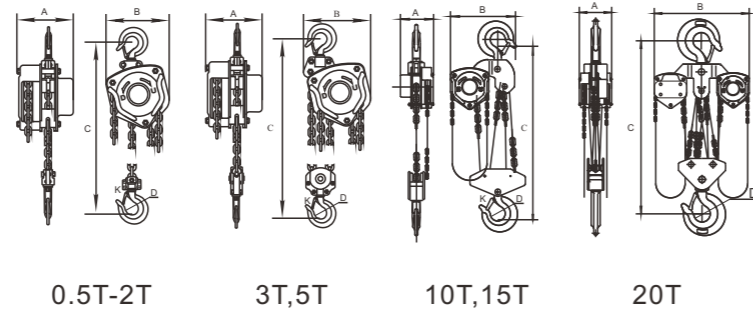

HSZ-B Series Manual Chain Block Specifications



- G80 alloy steel load chain with black oxide finish for rust resistance
- Zinc plated hand chain always keeps your hands clean
- Quenched and tempered gear set provide high strength and durable wear resistance
- Automatic double pawl brake system offers double safety
- Industrial grade powder painting meet RoHS requirement

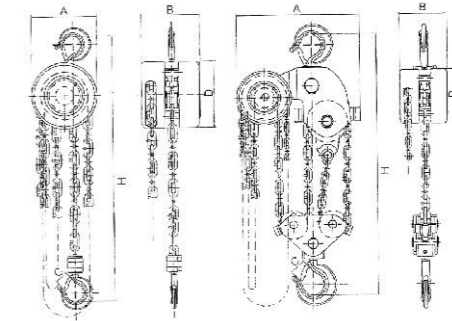

Model		HSZ-0.5	HSZ-1	HSZ-1.5	HSZ-2	HSZ-3	HSZ-5	HSZ-10	HSZ-20
Capacity	tons	0.5	1	1.5	2	3	5	10	20
Standard lift	m	2.5	2.5	2.5	3	3	3	3	3
Running test load	kN	7.5	15	22.5	30	45	75	150	300
Effort required to lift rated load	N	221	304	343	410	343	414	414	414x2
Diameter of load chain	MM	6	6	8	6	8	10	10	10
Strands of load chain		1	1	1	2	2	2	4	8
Dimensions	A	113	126	141	141	142	163	163	191
	B	125	147	183	183	183	215	404.5	595
	C	255	306	368	368	486	616	750	1000
	D	36	40	45	50	58	64	85	110
	K	30	34	38	41	48	52	64	85
Net weight	kg	8.5	11	18	18	27	42	83	193
Packing measurement	cm	25x18x13.5	25x20x15	33x25x16	33x25x16	33x27x16	43x34x19	50x41x21	64x38x64
Extra weight per meter of extra lift	kg	1.7	1.7	2.3	2.3	3.7	5.6	9.7	19.4

Model		HSZ-0.5	HSZ-1	HSZ-1.5	HSZ-2	HSZ-3	HSZ-5	HSZ-10	HSZ-20
Capacity	tons	0.5	1	1.5	2	3	5	10	20
Standard lift	m	2.5	2.5	2.5	3	3	3	3	3
Running test load	kN	7.5	15	22.5	30	45	75	125	250
Effort required to lift rated load	N	225	309	343	314	343	383	392	392x2
Diameter of load chain	MM	6	6	8	6	8	10	10	10
Strands of load chain		1	1	1	2	2	2	4	8
Dimensions	A	120	142	178	142	178	210	358	580
	B	108	122	139	122	139	162	162	189
	C	315	335	435	470	555	720	820	1040
	D	35	40	45	50	55	65	85	110
	K	23	26	29	34	37	41	50	80
Net weight	kg	8	10	16	14	24	36	68	155
Packing measurement	cm	28x21x17	30x24x18	34x29x20	33x25x19	38x30x20	45x35x24	62x50x28	70x46x75
Extra weight per meter of extra lift	kg	1.7	1.7	2.3	2.5	3.7	5.6	9.7	19.4