



CHONGQING TITAN SUHE TECH CO., LTD
Address: 8-3, A Tower, Xiexin Building, Hongjin Road,
Yubei District, Chongqing, China

Tel: 0086-23-67109118
Fax: 0086-23-67109618

What's app/wechat : +8617815375169
Email: sales101@titansuhe.com

WWW.TITANSUHELIFT.COM

HSZ-A622 Series Heavy Duty Manual Chain Block Specifications

HSZ-A619 Series Manual Chain Block Specifications



- G80 alloy steel load chain with black oxide finish for rust resistance
- Zinc plated hand chain always keeps your hands clean
- Quenched and tempered gear set provide high strength and durable wear resistance
- Automatic double pawl brake system offers double safety
- Industrial grade powder painting meet RoHS requirement
- Type tested with mini. 4 times safety factor and 1500 cycles life test,
- Meet EN13157 and ANSIB30.6, AS1418 Specifications.

- G80 alloy steel load chain with black oxide finish for rust resistance
- Zinc plated hand chain always keeps your hands clean
- Quenched and tempered gear set provide high strength and durable wear resistance
- Automatic double pawl brake system offers double safety
- Industrial grade powder painting meet RoHS requirement
- Type tested with mini. 4 times safety factor and 1500 cycles life test
- Meet EN13157 and ANSIB30.6, AS1418 Specifications.

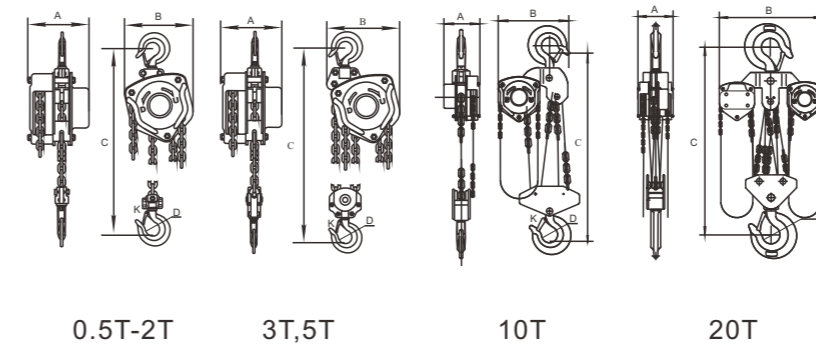
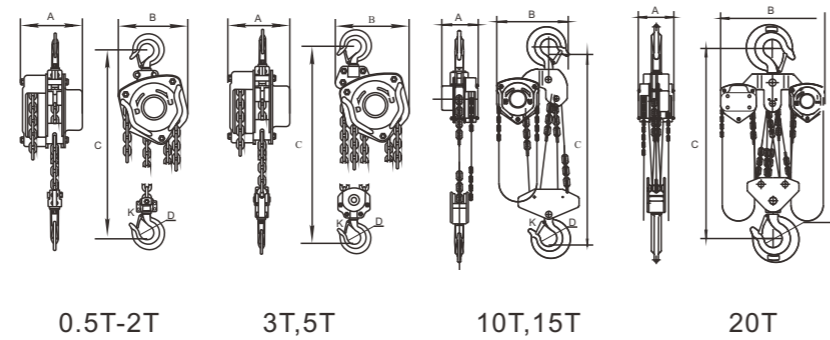

Model		HSZ-0.5	HSZ-1	HSZ-1.5	HSZ-2	HSZ-3	HSZ-5	HSZ-7.5	HSZ-10	HSZ-15	HSZ-20	HSZ-30
Capacity	tons	0.5	1	1.5	2	3	5	7.5	10	15	20	30
Standard lift	m	3	3	3	3	3	3	3	3	3	3	3
Running test load	kN	7.5	15	22.5	30	45	75	112.5	150	225	300	450
Effort required to lift rated load	N	225	300	350	310	350	400	415	410	420	410x2	410x2
Diameter of load chain	MM	5	6	7.1	8	7.1	9	10	9	10	9	10
Strands of load chain		1	1	1	1	2	2	3	4	6	8	12
Dimensions	A	132	152	155	185	152	185	189	185	194	220	274
	B	152	157	180	207	207	267	380	380	400	440	649
	C	315	355	375	430	500	680	650	750	880	940	1100
	D	34	38	48	48	50	57	72	80	85	106	120
	K	27	27	36	36	38	48	47	51	58	70	80
Net weight	kg	8.5	11	14.5	17.5	20.5	36.5	44	60	102	146	246
Packing measurement	cm	24.5x19x18	26x19x19	30.5x21x19	30x24x23	34x24x19	49x29x23	47x42x23	47x42x22	97x48x23	80x70x24	80x70x37
Extra weight per meter of extra lift	kg	1.3	1.6	2.2	2.3	3.2	4.5	7.5	8.1	14	16.2	28.2

Model		HSZ-0.5	HSZ-1	HSZ-1.5	HSZ-2	HSZ-3	HSZ-5	HSZ-7.5	HSZ-10	HSZ-15	HSZ-20	HSZ-30
Capacity	tons	0.5	1	1.5	2	3	5	7.5	10	15	20	30
Standard lift	m	3	3	3	3	3	3	3	3	3	3	3
Running test load	kN	7.5	15	22.5	30	45	62.5	112.5	125	225	250	450
Effort required to lift rated load	N	231	309	320	360	340	414	415	414	420	410x2	410x2
Diameter of load chain	MM	6	6	8	8	8	10	10	10	10	10	10
Strands of load chain		1	1	1	1	2	2	3	4	6	8	12
Dimensions	A	131	140	161	161	161	186	189	207	194	215	274
	B	127	158	174	187	199	253	380	398	400	650	649
	C	270	317	399	414	465	636	650	798	880	890	1100
	D	35	35.5	45	42.5	50	64	72	85	85	110	120
	K	30	28	36	33.5	40	50	47	64	58	85	80
Net weight	kg	10	12	19	20	27	45.5	44	83	102	193	246
Packing measurement	cm	22x15x19.5	23x18x19.5	28x21x24	28x21x24	32x21x26	40x21x31	47x42x23	50x41x21	97x48x23	64x38x64	80x70x37
Extra weight per meter of extra lift	kg	1.8	2.4	2.4	2.4	3.8	5.4	7.5	9.8	14	19.6	28.2